

Laser Displacement Sensor Communication Converter

BD-C Series INSTRUCTION MANUAL

TCD230017AB

Autonics

Thank you for choosing our Autonics product.

Read and understand the instruction manual and manual thoroughly before using the product.

For your safety, read and follow the below safety considerations before using. For your safety, read and follow the considerations written in the instruction manual, other manuals and Autonics website.

Keep this instruction manual in a place where you can find easily.

The specifications, dimensions, etc are subject to change without notice for product improvement. Some models may be discontinued without notice.

Follow Autonics website for the latest information.

Safety Considerations

- Observe all 'Safety Considerations' for safe and proper operation to avoid hazards.
- ⚠ symbol indicates caution due to special circumstances in which hazards may occur.

⚠ Warning Failure to follow instructions may result in serious injury or death

01. Fail-safe device must be installed when using the unit with machinery that may cause serious injury or substantial economic loss. (e.g. nuclear power control, medical equipment, ships, vehicles, railways, aircraft, combustion apparatus, safety equipment, crime/disaster prevention devices, etc.)

Failure to follow this instruction may result in personal injury, economic loss or fire.

02. Do not use the unit in the place where flammable/explosive/corrosive gas, high humidity, direct sunlight, radiant heat, vibration, impact or salinity may be present.

Failure to follow this instruction may result in explosion or fire.

03. Do not disassemble or modify the unit.

Failure to follow this instruction may result in fire.

04. Do not connect, repair, or inspect the unit while connected to a power source.

Failure to follow this instruction may result in fire.

05. Check 'Connections' before wiring.

Failure to follow this instruction may result in fire.

⚠ Caution Failure to follow instructions may result in injury or product damage

01. Use the unit within the rated specifications.

Failure to follow this instruction may result in fire or product damage.

02. Use a dry cloth to clean the unit, and do not use water or organic solvent.

Failure to follow this instruction may result in fire.

Cautions during Use

- Follow instructions in 'Cautions during Use'. Otherwise, it may cause unexpected accidents.
- Do not install where strong magnetic or electric field exist. Otherwise, the resolution may be adversely affected.
- Wire as short as possible and keep away from high voltage lines or power lines, to prevent surge and inductive noise.
- For the optimized performance, it is recommended to measure after 30 minute from supplying power.
- When detecting with the maximum sensitivity, an error may occur depending on each characteristic deviation.
- It is recommended to use Autonics communication converter. Please use twisted pair wire, which is suitable for RS485 communication.
- This unit may be used in the following environments.
 - Indoors (in the environment condition rated in 'Specifications')
 - Altitude max. 2,000 m
 - Pollution degree 2
 - Installation category II

Proper Usage

Before using this communication converter unit, depending on the usage environment, keep following items handy. Visit our web site (www.autonics.com) to download.

- atDisplacement program, manual
- BD Series manual
- Communication converter SCM Series Driver, instruction manual

Manual

For the detail information and instructions, please refer to the manual, and be sure to follow cautions written in the technical descriptions (catalog, website). Visit our website (www.autonics.com) to download manuals.

Software

Download the installation file and the manuals from the Autonics website.

■ atDisplacement

atDisplacement is a PC software for BD series laser displacement sensors. It is available for parameter setting, monitoring and data management.

Visit our website (www.autonics.com) to download the user manual and the program.

Product Composition

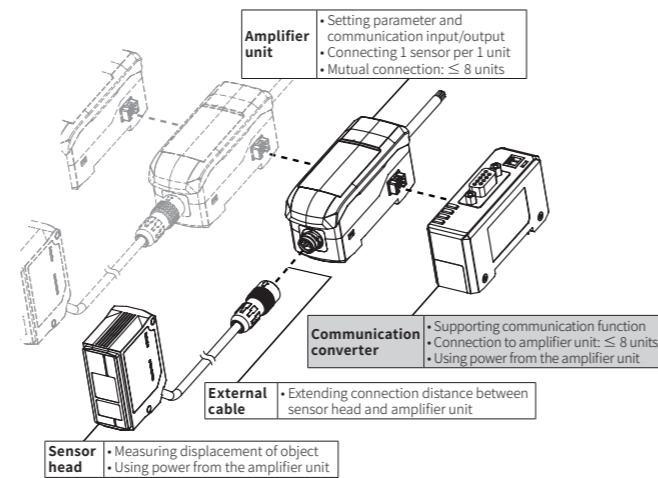

Specifications

Model	BD-CRS
Supported amplifier	Amplifier unit (BD-A1) ⁰¹⁾
Power supply	From the amplifier unit (BD-A1) (12 - 30 VDC=)
Power Consumption	≤ 2.3 W
Communication Protocol	Modbus RTU
Connection type	RS-232C, RS-485
Communication speed	9600, 19200, 38400, 115200 bps (default)
Function	Executes every BD-Series feature, sets parameter and real-time monitoring by external device (Master)
Ambient temperature	-10 to 50 °C, Storage: -15 to 60 °C (no freezing or condensation)
Ambient humidity	≤ 85%RH, Storage: ≤ 85%RH (no freezing or condensation)
Vibration	1.5 mm amplitude at frequency of 10 to 55 Hz in each X, Y, Z direction for 2 hours
Shock	300 m/s ² (≈ 50 G) in each X, Y, Z direction for 3 times
Protection structure	IP40 (IEC standard)
Material	Case: PC
Accessory	Side connector, Connector for RS485
Sold separately	Communication converter: SCM Series
Approval	CE, RoHS, REACH, ENEC, ETL
Unit weight (packaged)	≈ 49 g (≈ 91 g)

01) Communication converter (BD-C) firmware 5.0 and later only supports amplifier unit (BD-A1) firmware 5.0 and later.

Dimensions

- Unit: mm, For the detailed drawings, follow the Autonics website.

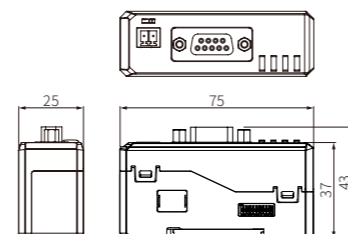

Unit Descriptions

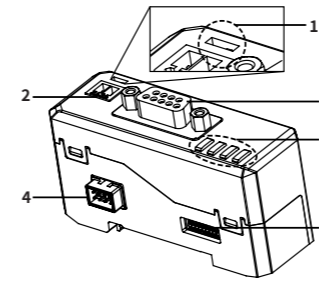

1. RS485 terminating switch

Refer to 'Connection - RS485 - terminating switch'.

2. RS485 connector
Refer to 'Connection - RS485 - Communication pin'.

3. RS232C connector
Refer to 'Connection - RS232C'.

4. Side connector
A connector for connecting between communication converter and amplifier unit.

5. Communication setting switch

Refer to 'Communication setting - Communication setting switch'.

6. Status Indicator

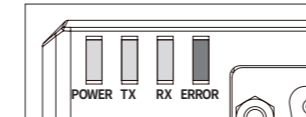

Display (Color)	Name	Color	Status	Description	Troubleshooting
POWER (Green)	Power	green	On	Power is supplied.	-
			Off	Power is not supplied.	After checking the connection between communication converter and amplifier unit correctly, reconnect the device.
TX (Green)	Communication output	green	Flash	Signal is outputting.	-
			Off	Signal is not outputting.	-
RX (Green)	Communication input	green	Flash	Signal is inputting.	-
			Off	Signal is not inputting.	-
ERROR (Red)	Communication error	red	On	Connection is bad between communication converter and amplifier unit.	After checking the connection between communication converter and amplifier unit correctly, reconnect the device.
			Flash	Communication is bad between communication converter and amplifier unit.	Apply noise prevention to communication converter and amplifier unit.
			Off	Operation is normal.	-

Connections

■ RS232C

- When connecting BD-C to external device, use D-SUB 9 pin cable.

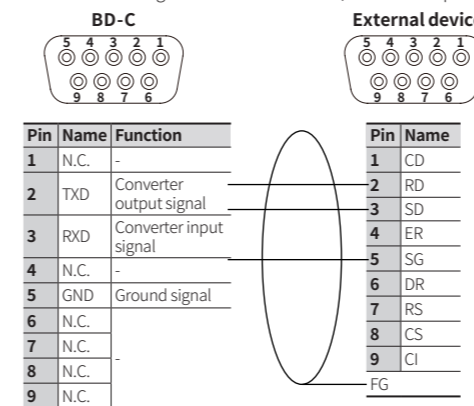

■ RS485

Communication pin

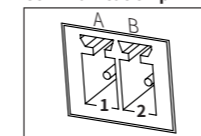

Pin	Name	Function
1	A(+)	RS485 + signal
2	B(-)	RS485 - signal

Terminating switch



Set the switch to 'RT' when the communication converter is connected to the terminal of RS485 communication connection, and set to 'OFF' when it is in the middle of the communication connection.

Communication Setting

■ Communication setting switch

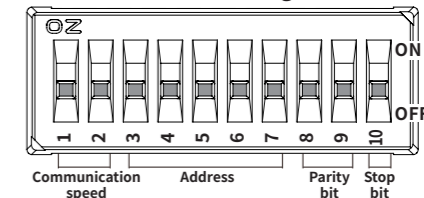

Switch 1, 2: Communication speed

1	2	Communication speed
ON	ON	9,600 bps
OFF	ON	19,200 bps
ON	OFF	38,400 bps
OFF	OFF	115,200 bps

Switch 3 to 7: Address

Switch No.	3	4	5	6	7	Address
Binary digit OFF = 0 ON = 1	2 ¹	2 ²	2 ³	2 ⁴	2 ⁵	Address=switch3×2 ⁴ +switch4×2 ³ +switch5×2 ² +switch6×2 ¹ +switch7×2 ⁰ +1
Address 1	OFF	OFF	OFF	OFF	OFF	1=0×2 ⁴ +0×2 ³ +0×2 ² +0×2 ¹ +0×2 ⁰ +1
Address 2	OFF	OFF	OFF	OFF	ON	2=0×2 ⁴ +0×2 ³ +0×2 ² +0×2 ¹ +1×2 ⁰ +1
Address 3	OFF	OFF	OFF	ON	OFF	3=0×2 ⁴ +0×2 ³ +0×2 ² +1×2 ¹ +0×2 ⁰ +1
..
Address 16	OFF	ON	ON	ON	ON	16=0×2 ⁴ +1×2 ³ +1×2 ² +1×2 ¹ +1×2 ⁰ +1
..
Address 31	ON	ON	ON	ON	OFF	31=1×2 ⁴ +1×2 ³ +1×2 ² +1×2 ¹ +0×2 ⁰ +1
Address 32	ON	ON	ON	ON	ON	32=1×2 ⁴ +1×2 ³ +1×2 ² +1×2 ¹ +1×2 ⁰ +1

Switch 8, 9: Parity bit

Parity bit	8	9
Even	ON	ON
Odd	OFF	ON
None	ON	OFF
None	OFF	OFF

Switch 10: Stop bit

Stop bit	10
2 bit	ON
1 bit	OFF

Installation Method

■ Mounting on DIN rail

Installation

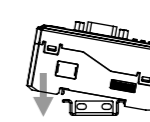

Insert bottom holder of communication converter to 35 mm width DIN rail and Push the front part of the unit to arrow direction to mount.

Separation

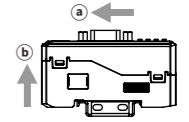

Push amplifier unit to ① direction and pull the assembly part to ② direction to detach.

■ Connecting to amplifier unit

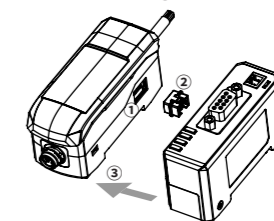

Remove the side cover (①) at the connecting side and connect the side (②) connector to the units. After mounting amplifier unit and communication unit on DIN rail, push it to arrow direction (③) tightly.

- In case of disconnecting, follow the upper sequence reversely.
- Check the firmware version when connecting to the amplifier unit.

■ Communication system configuration

Distinguishing master/slave amplifier units

Comm. converter Amplifier unit • Max. 8 units

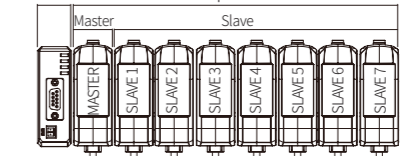

When the power cable direction is down, the amplifier at the left end is the master unit, and the channel number of slaves increases sequentially to the right. Communication converter is connected to the left side of master amplifier unit.

Precautions when connecting amplifier unit

- Mount on DIN rail.
- Do not supply the power when adding amplifier unit.
- Supply power to each connected amplifier unit at the same time.
- Up to 8 amplifier units can be connected, and only 1 calculation function can be performed per 1 group of mutually connected amplifiers.
- When the calculation function is activated, the setting values (SV) of the slave units are disable and the mutual interference prevention function for sensor heads is executed automatically.