

A-INL-M25-P-LG - Counter nut

1417661

<https://www.phoenixcontact.com/pc/products/1417661>



Please be informed that the data shown in this PDF document is generated from our online catalog. Please find the complete data in the user documentation. Our general terms of use for downloads are valid.

Counter nut, for threads M25 x 1.5, color: light grey



Commercial data

Item number	1417661
Packing unit	5 pc
Minimum order quantity	1 pc
Product key	BF7DZX
Catalog page	Page 686 (C-2-2019)
GTIN	4055626121642
Weight per piece (including packing)	3.93 g
Weight per piece (excluding packing)	3.184 g
Customs tariff number	39269097
Country of origin	TR

A-INL-M25-P-LG - Counter nut

1417661

<https://www.phoenixcontact.com/pc/products/1417661>

Technical data

Product properties

Product type	Flat nut
Thread type	M25

Dimensions

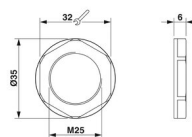
Dimensional drawing	
Length	6 mm
Diameter	25 mm
Connecting thread diameter	25 mm
Wrench size, counter nut	32 mm
Hexagon angular dimension	35 mm
Thread type connection side	M25 x 1.5
Thread pitch	1.5 mm

Material specifications

Material	PA 6.6 GF
----------	-----------

Cable/line

Halogen-free	yes
--------------	-----

Environmental and real-life conditions

Ambient conditions

Ambient temperature (operation)	-40 °C ... 100 °C
---------------------------------	-------------------

A-INL-M25-P-LG - Counter nut

1417661

<https://www.phoenixcontact.com/pc/products/1417661>



Drawings

Dimensional drawing

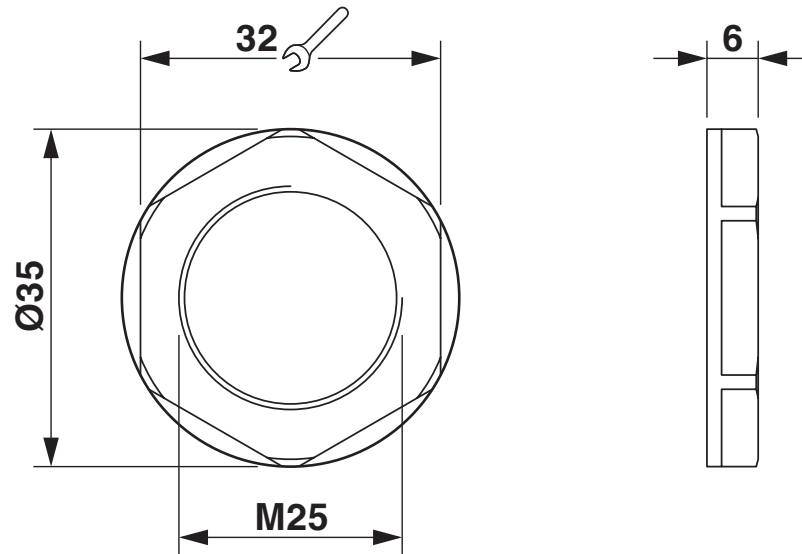

A-INL-M25-P-LG - Counter nut



1417661

<https://www.phoenixcontact.com/pc/products/1417661>

Classifications

ECLASS

ECLASS-11.0	27144424
ECLASS-13.0	27140807

ETIM

ETIM 8.0	EC000940
----------	----------

UNSPSC

UNSPSC 21.0	31161700
-------------	----------

A-INL-M25-P-LG - Counter nut



1417661

<https://www.phoenixcontact.com/pc/products/1417661>

Environmental product compliance

China RoHS	Environmentally friendly use period: unlimited = EFUP-e No hazardous substances above threshold values
------------	---

Phoenix Contact 2023 © - all rights reserved
<https://www.phoenixcontact.com>

PHOENIX CONTACT GmbH & Co. KG
Flachmarktstraße 8
D-32825 Blomberg
+49 (0) 5235-3 00
info@phoenixcontact.com